

338 Federal

Lab Notes:

The 338 Federal cartridge was introduced by Federal Cartridge in 2006 as a commercial version of the 338-08 wildcat.

The new cartridge is a modern alternative to classic woods cartridges such as the 35 Remington, 348 Winchester, and 358 Winchester. The 338 Federal does everything the old veterans can, but has a flatter trajectory. That means extra range for when you walk out of the woods into open areas.

Factory ammo is loaded with 180-, 185-, and 210-grain bullets with nominal velocities ranging from 2630 to 2830 feet/sec. Two of Speer's 338-caliber component bullets are excellent choices for the 338 Federal. The 200-grain Hot-Cor® spitzer is the best all-around

bullet. It can be safely driven at nearly 2600 feet/sec. When hunting heavier game at close ranges, switch to the 225-grain Speer boat tail spitzer. Three propellants stood out in this cartridge with either bullet weight: Alliant Reloder 15, Hodgdon Varget, and Winchester 748. Several loads are compressed; plan on using a funnel with a long drop tube to making charging easier.

Owners of custom 338-08 rifles should not use factory 338 Federal ammunition; many custom 338-08 chambers are slightly shorter than the 338 Federal case.

Maximum loads shown remain within the 62,000 psi pressure limit established for the 338 Federal.

Test Conditions—Case: Federal®; Primer: Federal 210; Test Firearm: Univ. Receiver; Barrel: HS Precision 24" 1-10" twist

200 gr Speer Hot-Cor Spitzer SP #2405

COAL tested: 2.820"
BC: 0.426 • SD: 0.250

225 gr Speer Boat Tail Spitzer SP #2406

COAL tested: 2.820"
BC: 0.497 • SD: 0.281

Propellant	Start Charge, gr	Start Charge Velocity	MAX Charge, gr	MAX. Charge Velocity
Reloder® 15	44.0	2508	46.0C	2598
Varget	45.0	2485	47.0C	2571
748	45.5	2504	47.5	2570
Ramshot TAC	42.0	2421	44.0	2504
H322	38.0	2303	40.0	2451
Reloder 10X	36.5	2345	38.5	2444
XMR 2015	38.0	2303	40.0	2404
Reloder 7	34.5	2306	36.5	2403
IMR 4198	33.5	2268	35.5	2368

Propellant	Start Charge, gr	Start Charge Velocity	MAX Charge, gr	MAX. Charge Velocity
Reloder 15	42.0	2350	44.0C	2440
Varget	42.5	2326	44.5	2408
748	42.5	2309	44.5	2392
Ramshot TAC	40.0	2277	42.0	2368
IMR 3031	37.0	2204	39.0	2323
Reloder 10X	35.0	2207	37.0	2299
H322	35.5	2174	37.5	2276
Reloder 7	33.0	2161	35.0	2256
XMR 2015	35.5	2139	37.5	2237

Bold type denotes **MAXIMUM** loads; use with caution. C—compressed load

COAL values shown are *guidelines*, not gospel. It is the responsibility of the reloader to determine the safe max COAL for his firearm and bullet choice.



338 Federal

Max. Case Length: 2.015"
Trim-to Length: 2.005"
Max. Loaded Length: 2.820"
Min. Loaded Length: 2.490"
RCBS® Shellholder: #3

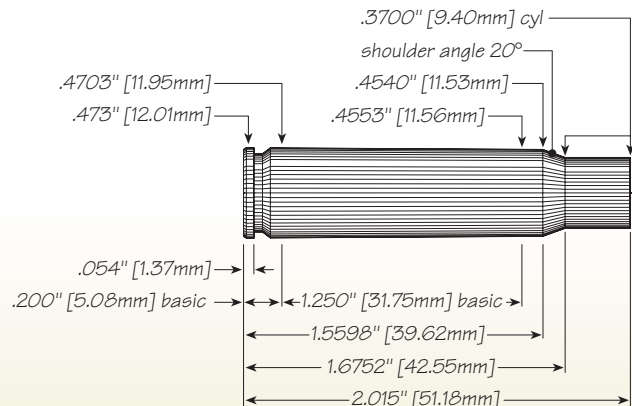

H18M rev issue

© 2006 ATK, Inc. All rights reserved.

Speer, Hot-Cor, Federal, RCBS, and Reloder are registered trademarks of ATK, Inc and its subsidiary companies.

WARNING: Improper handloading practices can result in serious personal injury and/or property damage. Refer to the current SPEER Reloading Manual for handloading instructions. Be thoroughly familiar with those instructions before using these loads. As ATK/CCI-SPEER has no control over individual handloading practices or the condition of firearms in which the resulting ammo may be used, we disclaim all liability for any damages that may result from the use of this information.